



# Perma-Crimp™ Hydraulic Hose Crimpers

## PC200 Series Operators Manual

Including PC200-1P, PC200-2P and PC200-3P

# Table of Contents

Component Identification	3
PC200 Specifications	4
Initial Setup Instructions	5
Controller Operation-Crimping Procedure	6
Intermediate Die Installation	12
Hydraulic Die Installation	13
Coupling Stop Installation	14
Lubrication	15
Troubleshooting	16
PLC Reset/Relay Replacement	17
Part Numbers	18
Warranty Information	19

## Equipment Warning

### Proper assembly of Continental ContiTech hose and fittings

Continental ContiTech hose, fittings and crimping equipment work together to provide an efficient and reliable hose connection. Continental ContiTech hose and fittings are part of an engineered system and are to be used in accordance with Continental ContiTech specifications. Using non-Continental ContiTech components may produce an assembly that does not meet rated performance. **Continental ContiTech does not warrant, expressly or by implication, hose assemblies that do not incorporate Continental ContiTech hose and fittings, or are not crimped in accordance with Continental ContiTech process specifications.**

Buyers may elect to attach additional or non-standard parts or equipment, or to use different manufacturing specifications as necessary to meet the requirements of the buyer or the customer's application. In such cases, the buyer has sole responsibility to qualify the hose for the applications as necessary to ensure performance capability.

For guidance in the assembly of Continental ContiTech hose and couplings, please refer to the Continental ContiTech Crimp Specifications Manual. Information in this catalog is believed to be accurate, but is not warranted and is subject to change without prior notice. For the most current product information, check the Continental ContiTech website at [www.contitech.us](http://www.contitech.us).

For technical assistance, call customer service at **1-800-235-4632**.

# PC200 Component Identification

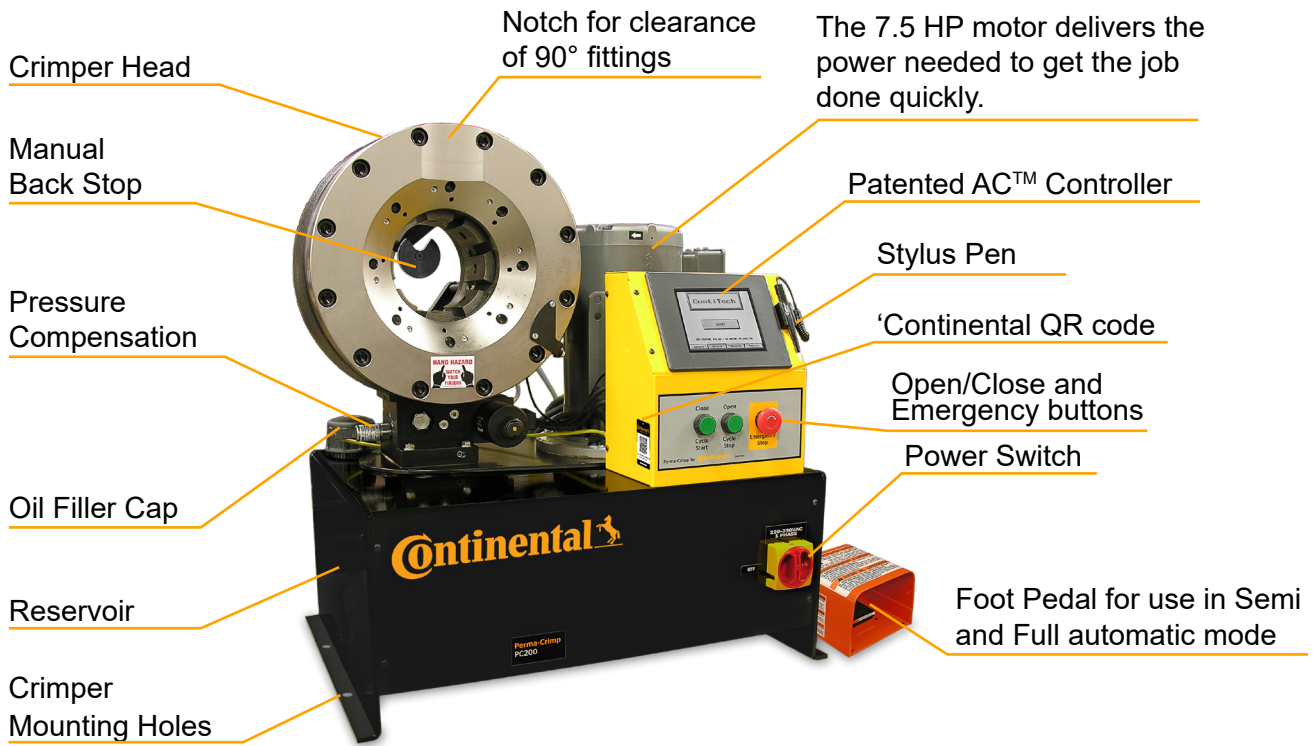

Small Footprint for minimum use of space



USB Port and Foot Switch Plug-in Port



Serial Tag Location



Oil Level Sight Glass

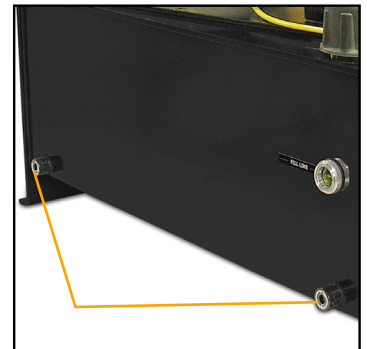

Tank Drain and Oil Cooler Ports

**Do not operate the Continental ContiTech ACT™ Controller PC200 until you have read and fully understand this manual and the proper use of the crimper.** This manual is applicable to the PC200-1P, PC200-2P and PC200-3P crimpers. Crimpers are identical in componentry and crimping procedures. Note that the PC200-1P, PC200-2P and PC200-3P require different electrical hookups as power requirements differ from 220V to 480V, respectively

# PC200 Crimper Specifications

<b>Master Die Diameter</b>	168mm (6.62 in.)
<b>Master Die Inside Diameter</b>	130mm (5.11 in.)
<b>Maximum Swaging Range</b>	130mm (5.11 in.)
<b>Maximum Die Opening</b>	Die Closed Diameter + 38mm
<b>Crimper Dimensions</b>	18.5" deep x 27.5" wide x 31.5" high
<b>Weight</b>	573 lbs.
<b>Electrical Requirements</b>	PC200-1P – 220-240V/3 phase (standard) PC200-2P – 440-480V/3 phase (optional) PC200-3P-220-240V/single phase (optional)
<b>Motor</b>	PC200-1P, PC200-2P - 7.5 HP PC200-3P - 5 HP
<b>Reservoir Capacity</b>	8 U.S. gallons
<b>Oil Type</b>	ISO 46 Hydraulic Oil
<b>Adapter Dies</b>	130mm ID (standard)
<b>Hydraulic Dies</b>	Dies 99mm ID (included)
<b>Hose Capacity</b>	2" 6 Spiral Hydraulic Hose

Standard Dies			
Part #	ID	Part #	ID
PC200-8.5	8.5mm	PC200-41	41mm
PC200-12	12mm	PC200-45	45MM
PC200-14	14mm	PC200-50	50MM
PC200-16	16mm	PC200-56	56MM
PC200-19	19mm	PC200-62	62MM
PC200-23	23mm	PC200-69	69MM
PC200-27	27mm	PC200-74	74MM
PC200-31	31mm	PC200-78	78MM
PC200-34	34mm		

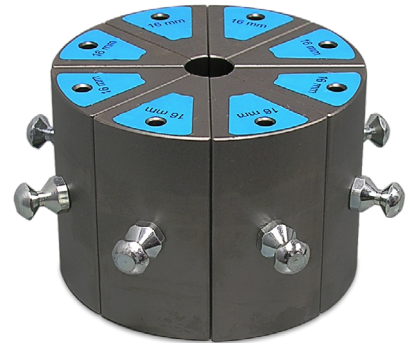

## Miscellaneous Parts

- PC200-MBS** – Included manual back stop
- PC200-EBS** – Optional automatic back stop
- PC900-AerosolLube** – High pressure grease in aerosol can
- PC200-Rack** – Optional Black die cabinet. Mounts below PC200 crimper  
20" deep x 30" wide x 29" high

PC200-Rack  
for PC200/PC400 Crimpers

# PC200 Initial Crimper Setup

## Follow these steps before using the crimper for the first time

- › Review instructions and identify all component parts before using crimper.
- › Crimper can produce 340 tons of force.
- › Keep both hands away from pinch points.
- › Consult the Continental ContiTech Crimp Specification Manual for correct crimper settings and crimp measurements.
- › Always wear eye protection.



## Installing crimper

- › Mount the crimper on a sturdy surface. Workbench should be able to support crimper weight of 573 lbs. Crimper can be mounted to optional die cabinet, which is designed to support the unit. Do not lift machine by the crimper head. Using a fork lift, lift the crimper under the tank.



- › Check reservoir oil level with sight glass at the rear of the crimper. The reservoir requires 8 gallons of ISO 46 hydraulic oil for a complete fill. If necessary, oil can be drained from either of the two ports at the bottom of the reservoir.

- › Check electrical circuit to be certain that it matches the crimper requirements shown on the tag attached to the crimper cord. The standard 7.5 HP motor (PC200-1) requires a 220-240V/3/phase hookup, and the optional 7.5 HP motor (PC200-2) requires a 440-480V/3/phase electrical hookup. The optional 5.0 HP motor (PC200-3) requires a 220-240V/single phase hookup.



- › Make certain that the motor rotates in the direction of the arrow shown on the motor housing. If the motor rotation is opposite the direction of the arrow, reverse any two hot wires in the electrical plug of a 3 phase circuit. Damage to the pump can result if the motor does not rotate in the correct direction.

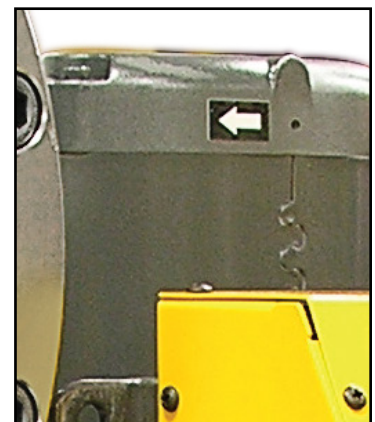

# Controller Quick Start

## ACT™ controller quick start

Patent number 7,383,709

While the ACT™ crimper has the ability to perform a number of fully automatic functions, manual operation is also possible.

To make a manual crimp, two numbers are needed:

**The closed diameter of the die** (in either inches or mm).

**The finished crimp diameter** (in either inches or mm).

That is all you need to know. ACT™ does the rest.



## To make a manual crimp

- › Press **START BUTTON**.
- › Select **CRIMP TO DIAMETER**.
- › Enter the closed diameter of the die set in either inches or mm and press **ENTER**.

**Note:** for a 25mm die, enter 2500. ACT™ will add the decimal point.



## Decimal point entry

For 1.56 inch entry, enter 1560 (controller supplies 3 places for entries in inches).

For a 50.0mm entry, enter 5000 (controller will supply 2 decimal places for entries in mm).

- › Enter the finished crimp diameter and press **ENTER**.
- › From the **ENTER CRIMP** screen, press the **MANUAL** button to put the crimper in manual mode.
- › Confirm that the die and finished crimp diameters are correct and that **MANUAL MODE** is displayed.
- › Press and hold the green **CLOSE** button until the crimper stops closing.
- › Check the final crimp diameter. If a minor correction is required, see [How to Make Minor Corrections](#).

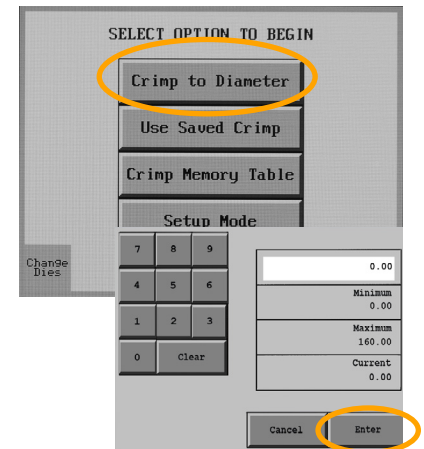

**Tip:** Pressing the **CHANGE DIES** button allows the crimper head to be fully opened or closed with the green **OPEN-CLOSE** buttons on the controller front panel. When the **CHANGE DIES** button is blinking, the dies can be opened and closed manually without altering any of the crimper settings.

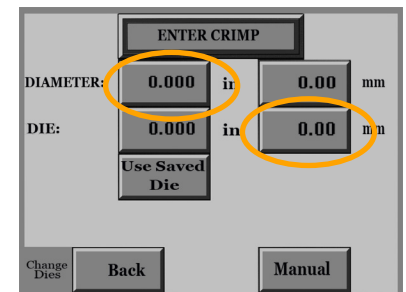

# Make Minor Corrections

## How to make minor corrections

› Due to variations in hose and fitting tolerances, a minor crimp adjustment may be required if the measured diameter of the final crimp is not within the hose and fitting manufacturer's specifications. ACT™ technology makes minor corrections a simple process which requires no addition or subtraction.

### If the finished crimp diameter is not within the required specifications

- › Press the **ADJUST CRIMP** button.
- › Enter the measured diameter of the fitting in either inches or mm (**do not enter the amount of correction**) and press **ENTER**.
- › Press **OK**.
- › Make another crimp and verify that the fitting is within specifications.

**Example:** If the hose and fitting manufacturer specifies that the finished crimp should measure 1.500 to 1.520 and the measured crimp diameter was 1.530, simply enter the measured diameter (1530 – controller will supply 3 decimal places) and press **SAVE**. The finished crimp diameter can be entered in either in. or mm and ACT™ will make the conversion.

While a single correction will usually bring the hose and fitting into specifications, the process can be repeated as many times as required.

## Patented ACT™ technology

On crimpers equipped with ACT™ controllers, the sensors, which sense the position of the dies, are supplemented by a pressure transducer that senses the “effort” required to make a crimp and compensates for variations in hose and fitting combinations. This unique feature means that the operator can enter the finished crimp diameter and will seldom, if ever, have to enter an offset to achieve the correct finished crimp diameter.

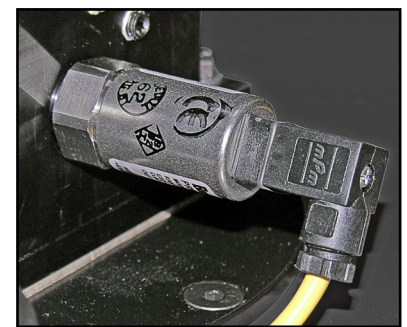
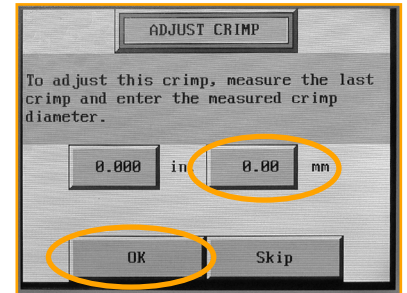
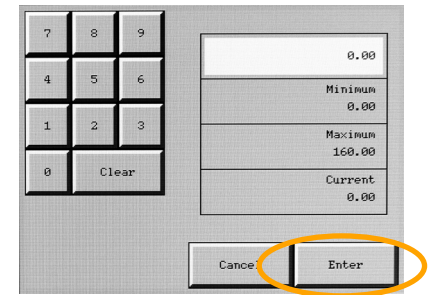
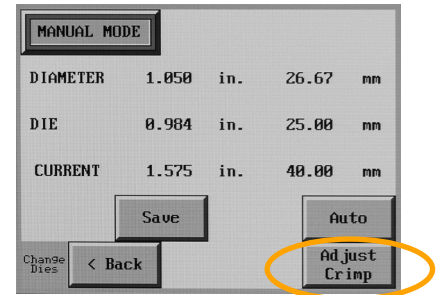

# Add/Recall a Saved Die

## How to add a saved die

Up to 50 different dies can be saved in the computer memory. These dies can be recalled in the set up process, eliminating the need to re-enter the die size each time.

## To enter a saved die

- › From the **OPTION** screen, press **SETUP MODE**.
- › Select **SAVED DIES**.
- › Select the save position (1-50) where the die is to be saved and press the **EDIT** button.
- › Enter a die description (up to 12 alpha/numeric characters).
- › Enter diameter units (inch or metric).
- › Enter the closed diameter of the die.
- › Press **SAVE** and **EXIT**.
- › The saved die will now appear on the **SELECTED DIE** screen. From this screen, individual dies can be cleared or edited.

## How to recall a saved die

- › Select **CRIMP TO DIAMETER**, and from the **OPTION** screen, select **USE SAVED DIE**.
- › Select the saved die (1-50) and press **LOAD** and then **OK**. The die parameters will now be used for the crimp process.
- › From the **ENTER CRIMP** screen press **MANUAL**.
- › The saved die will now be shown on the crimp parameters screen.

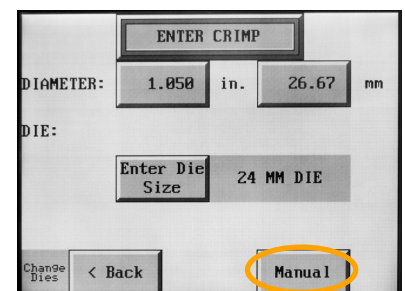
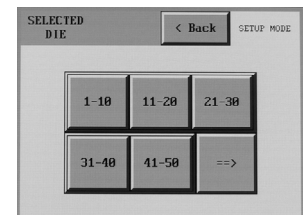
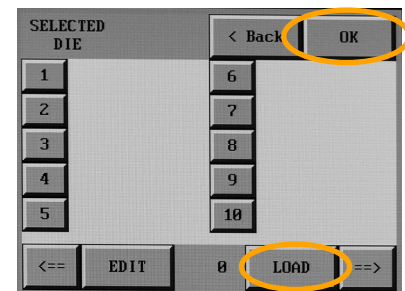
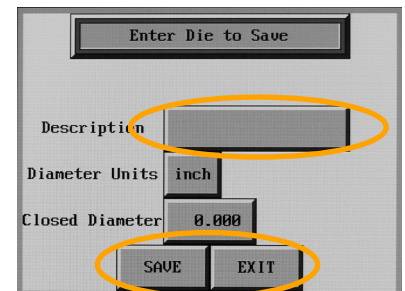
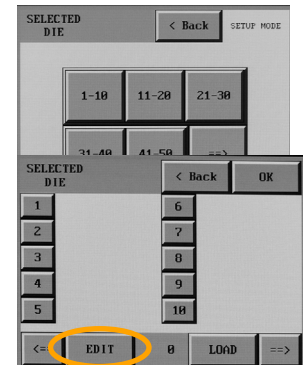
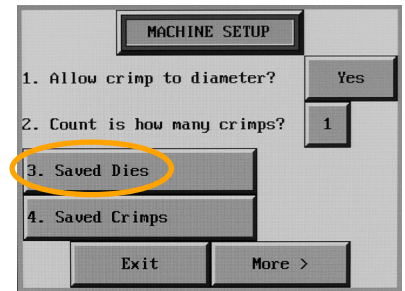

# Add/Recall a Saved Crimp

## How to add a saved crimp

- › Adjust the die diameter and crimp diameter as required and place the crimper in **MANUAL** mode.
- › Press **SAVE**.
- › Select a location (1-100) and press **EDIT**.
- › Enter a description (up to 12 characters).
- › Press **SAVE** and **EXIT**.
- › The die and crimp setting can now be recalled from the saved location as required.

## To recall saved crimp

- › Select **USE SAVED CRIMP** from the option screen.
- › Select a previously saved crimp from location 1-100.
- › Press **LOAD**.
- › Press **OK**.
- › The saved crimp will appear on the manual screen.

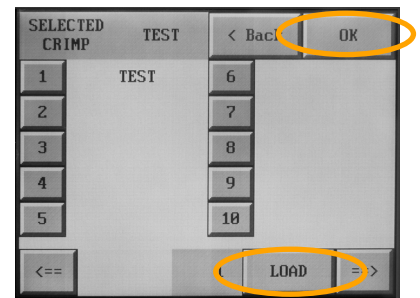
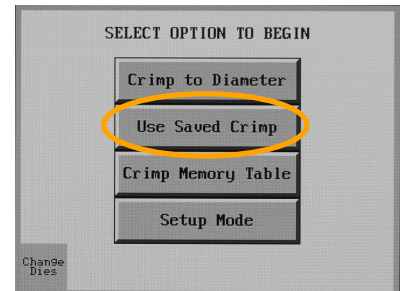
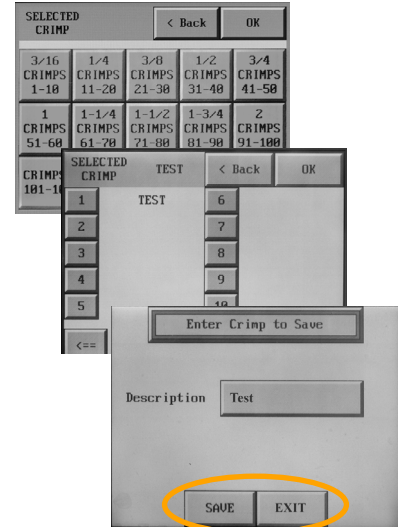
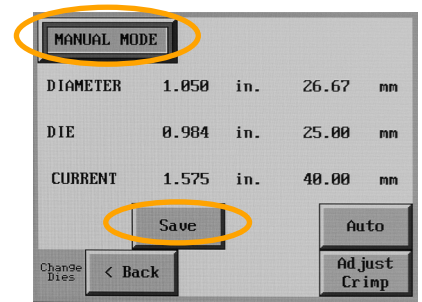

# Automatic Functions

With the crimper in **FULL-AUTO** mode additional functions are available:

- › The crimper will cycle automatically from the **CRIMP** button on the touch screen, the green **CYCLE START** button on the panel, or the foot switch.
- › To set the position to which the dies will retract, close the crimper to the desired retract position prior to pressing the **FULL-AUTO** button.

**Note:** The retraction position must be set a minimum amount above the finished crimp diameter or the crimper will not retract. The minimum retraction diameters are:

- › PC200 Series – crimp diameter plus 2mm
- › PC400 Series – crimp diameter plus 3mm
- › Pressing the **FULL-AUTO** button will toggle the crimper into **SEMI-AUTO** mode. In **SEMI-AUTO** mode, pressing the **FOOT SWITCH** or the **CLOSE** button will close the crimper head, and releasing it will cause the head to stop closing. This mode allows the crimper to be jogged into position allowing more precise positioning of a fitting in the dies. Pressing the **SEMI-AUTO** button will toggle the crimper back to **FULL-AUTO** mode.

In **FULL-AUTO** mode, pressing the foot switch will start the crimp cycle and the dies will stop closing when the crimp cycle is complete.

- › The **COUNT** function is activated allowing the operator to monitor the number of crimps made.
- › A measurement can be required after a preset number of crimps. See [Set required measurement](#).

## Set required measurement

- › Press the **PRODUCTION** button.
- › Determine if 1 or 2 crimps will count as a crimp.
- › Toggle the **CRIMP ADJUSTMENT REMINDER** to **ON**.
- › Set the **COUNTS BETWEEN CRIMP MEASUREMENTS** to the desired number and press **OK**.
- › At the set interval, the **ADJUST CRIMP** screen will come up and the operator will be asked to measure the last crimp and enter a correction if required.

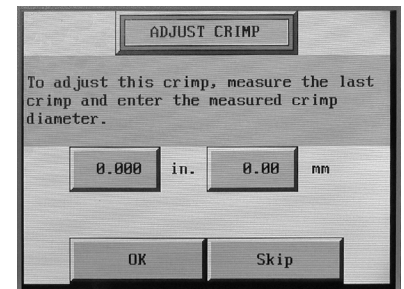
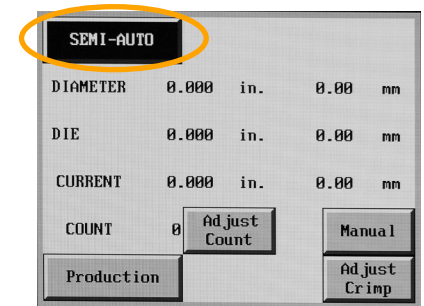
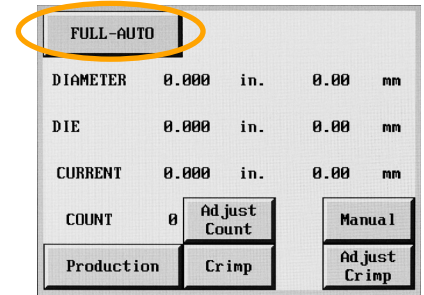

# Automatic Functions

## Adjust crimp count

If a production operation is interrupted for some reason, it is possible to reset the counter to where the operation was at the point of interruption.

- › Press the Adjust Count button from the auto crimp screen.
- › Press the Crimp Counter and reset the count to the desired point.

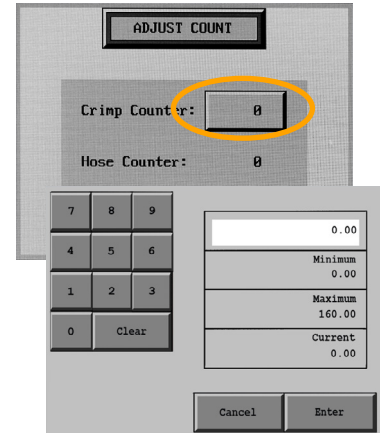
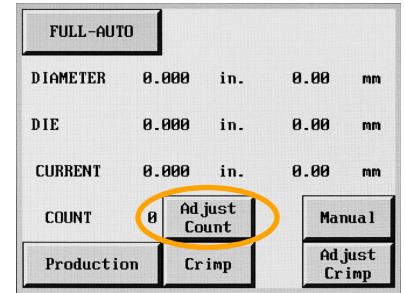

## ACT™ additional features

- › Additional features and functions of the ACT™ controller can be accessed by pressing the **MORE** button on the **MACHINE SETUP** screen.
- › When “Allow Crimp to Diameter” is set to “**YES**”, all of the adjustment functions of the crimper are available. When “Allow Crimp to Diameter” is set to “**NO**”, only the settings entered as a saved crimp can be used.
- › English or Spanish language options are available.
- › The “Use Pressure Compensation” is set to “**YES**” for all crimpers equipped with a pressure transducer. A security code is required to turn this function on or off.

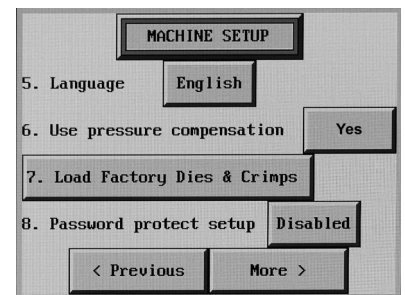

# Intermediate Die Installation

Both industrial and hydraulic dies are available for this crimper. Industrial dies are inserted directly into the master dies and hydraulic dies require an intermediate die. When using only hydraulic dies, removal of the intermediate dies should not be required.

The ID of the intermediate die must match the OD of the hydraulic die, or accurate crimps are not possible.

## Installation or removal of intermediate dies

› Turn on the crimper at the master power switch (See ACT™ Controller Instructions) and go to Manual mode.

› Bring the master dies to the full open position as shown in photo A, or to the position where the die removal tool can be inserted to release the retaining spring.

› Insert the die removal tool in the release hole to release the retaining spring as shown in photo B.

› Attach either an Intermediate Adapter Die or an Industrial Die to the Master Die as shown in photo C.

**Note:** The numbers stamped on the face of the die should face the operator.

**Note that on some crimpers the master dies must be slightly closed in order to completely insert the die removal tool.**

› Mount all 8 dies in a similar manner as shown in photo D.

› If industrial Dies are being used, proceed to the ACT™ Controller Operating instructions and set up the crimper for the correct crimp diameter.

› If Hydraulic Dies are being used, see Hydraulic Die Installation instructions.

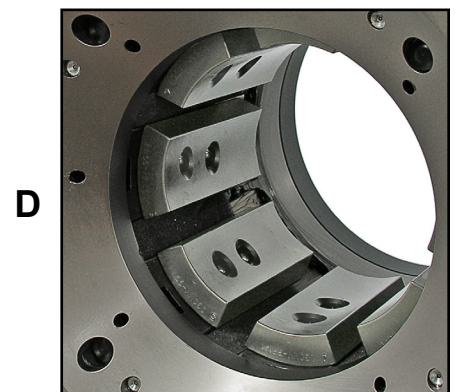
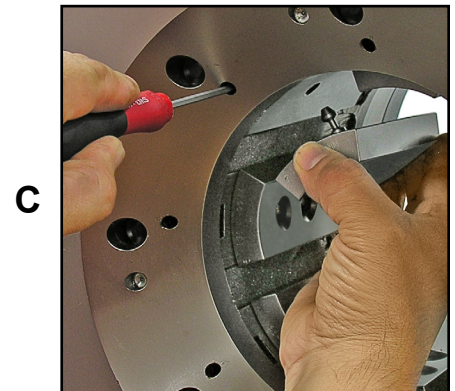
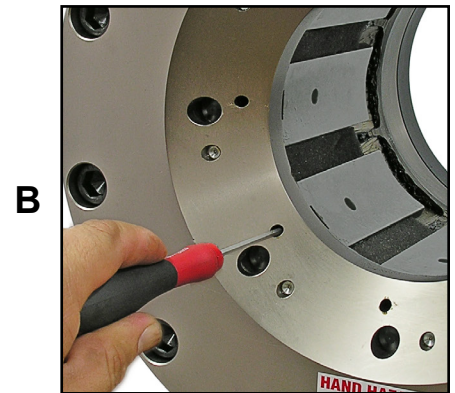
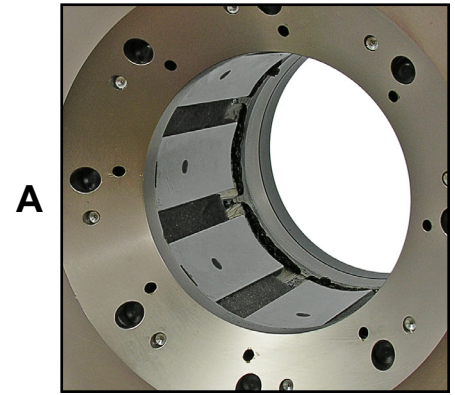

# Hydraulic Die Installation

› Install Intermediate Adapter Dies as shown previously making certain that the Intermediate Adapter Die I.D. matches the Hydraulic Die O.D.

› Bring the crimper head to fully opened position as shown in photo A.

› Install the Hydraulic Dies with the quick change tool as shown in photo B.

**Note:** The die size stamped on the face of the die should face toward the operator.

› Align the studs of the Hydraulic Dies with the holes in the Adapter Dies and **SLOWLY** close the crimper head on the die set as shown in photo C.

› Bring the crimper head to a fully closed position as shown in photo D.

› Remove the quick change tool as shown in photo E.

**Note:** The dies may also be inserted manually with the crimper head in the fully open position.

› Proceed to the ACT™ Controller Crimping Instructions to set up the crimper for the hose and fitting being crimped.

› For Hydraulic Die removal, place the crimper in manual mode or press **CHANGE DIES button on the controller**, and bring the crimper head to the fully closed position. Insert the quick change tool and open the crimper head, releasing the hydraulic dies from their spring retention holes.

A

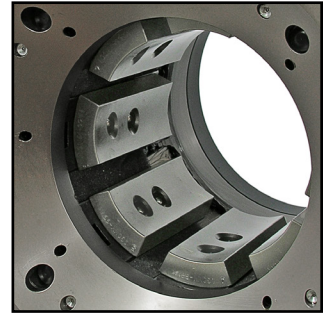

B



C

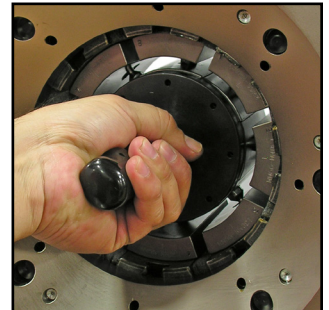

D

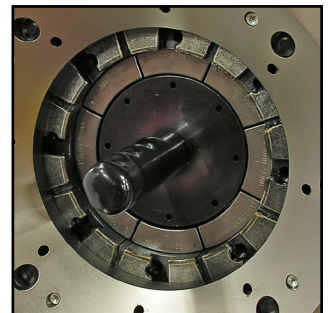

E

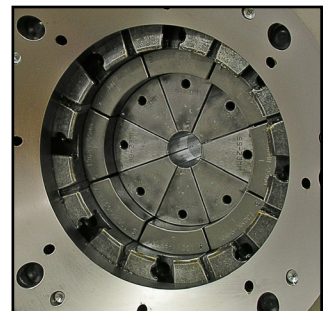

# AccuStop™ Coupling Stop

The AccuStop™ coupling stop eliminates guesswork, allowing the operator to visually observe exactly where the crimp will be positioned on the fitting without the need for trial and error and product scrap due to poor crimp positioning.

With the Coupling Stop retracted, load the appropriate set of dies and set crimp diameters as required.

With the crimper in the **MANUAL** mode, bring the dies to a fully closed position.

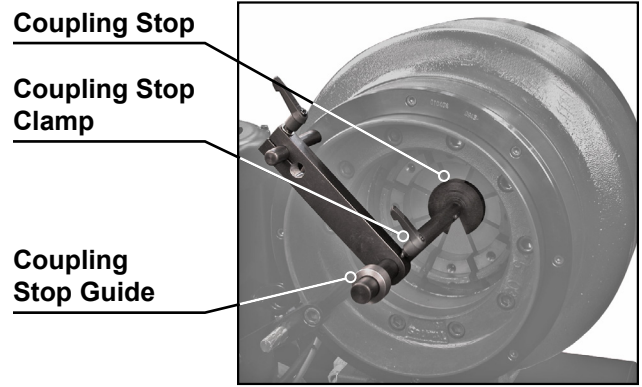

Loosen the Coupling Stop Clamp and position the Coupling Stop against the back face of the dies.



Slide the Coupling Stop Guide against the Coupling Stop Arm.

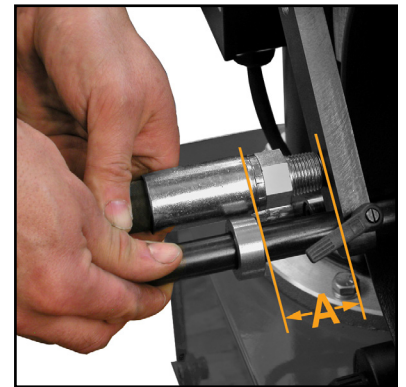

Hold the fitting against the Coupling Stop Arm withdraw the Coupling Stop Rod such that the Guide is aligned with the desired crimp position. Lock the Coupling Stop Clamp.

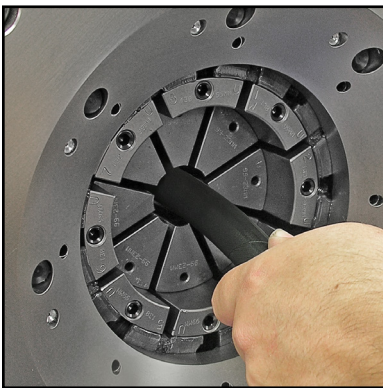

Position the fitting against the Coupling Stop and actuate the crimper in the normal manner.

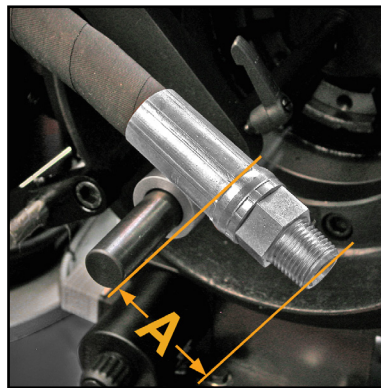

The dimension from the face of the fitting to the crimp position will now be the dimension established in the previous step.

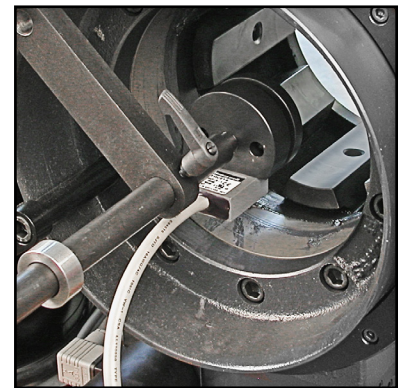

An electronic Coupling Stop is available. Set up is identical, but when the fitting touches the Coupling Stop, the crimp cycle will start automatically.

**CAUTION:** When using an electronic Coupling Stop, disconnect it from the controller prior to setup. Failure to do so will cause the crimper to actuate during the set up process.

# Lubrication and Maintenance

Check reservoir oil level with sight glass at the rear of the crimper. The reservoir requires 8 gallons of ISO 46 hydraulic oil for a complete fill. If necessary, oil can be drained from either of the two ports at the bottom of the reservoir.



Front flange bolts: Periodically, every 6-12 months depending upon usage, the front flange bolt torque should be checked. The correct torque is 330NM (243 ft-lbs.).

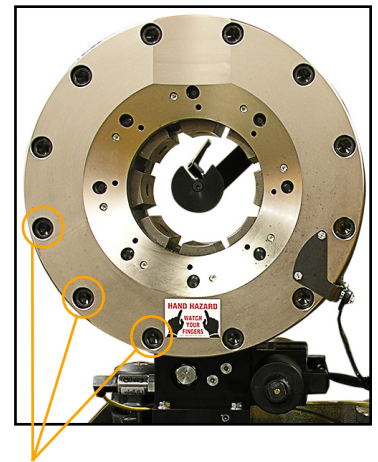

Front Flange Bolts

Proper lubrication is essential to prevent damage to the machine and to assure accurate crimping.

Lubricate the crimping head after each 100 crimping cycles or at the start of each shift if the crimper is used in a production setting.

- › Bring the master dies to the fully closed position and lubricate the die fingers through the 8 lubrication fittings in the front flange face.
- › Bring the dies to the fully open position and lubricate all 8 fittings again.

Use only a high-quality moly-disulfide grease. Failure to do so may result in damage to the wearing surfaces.

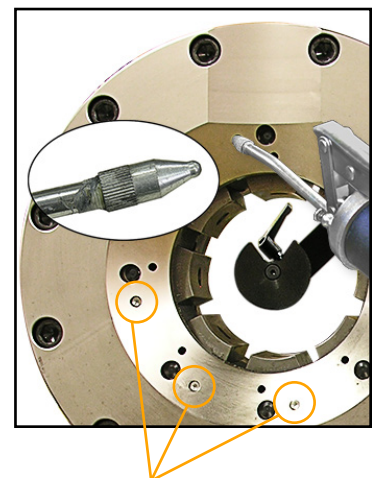

Grease Fittings

# Troubleshooting

## Problem: Crimper will not run at all.

- › Check the E-Stop switch to be certain that it is not depressed. A slight twist is required to release switch after it has been depressed.
- › PLC (Programmable Logic Control) must be reset (see PLC Reset procedure).

## Problem: Crimper is slow or non-functional.

- › Check supply voltage to see that it matches the voltage specified on the tag attached to the crimper. Many problems of this type are associated with inadequate voltage or power. The voltage and power measurements must be made while the crimper is running and under load.
- › Check motor rotation and be certain the motor rotates in the direction of the arrow on the motor housing. For three-phase units, rotation can be reversed by switching any two of the hot wires in the plug.

## Problem: Crimper will close on the fitting but does not develop adequate power.

- › Fitting is too large for selected crimp die. Select a crimp die that is closer to final crimp diameter. Machine has built-in safety bypass to protect internal components from damage due to incorrect die selection.
- › Check oil level. Position dies to the fully open position and check oil sight gauge in rear of machine. Be sure the oil level is in the middle of the sight glass. Use ISO 32 or 46 weight hydraulic oil.

## Problem: Crimper will not open to retract position in auto mode.

- › Retract position must be at least 2mm larger than the final crimp diameter for the PC200 Series Crimpers and at least 3mm larger than the final crimp setting for the PC400 Series Crimpers.

## Problem: Motor will not run or dies will not open or close.

- › See relay replacement.

If problem(s) persist, contact customer service for additional troubleshooting assistance.

# PLC Reset/Relay Replacement

## Electrical Panel (Front Cover Removed)

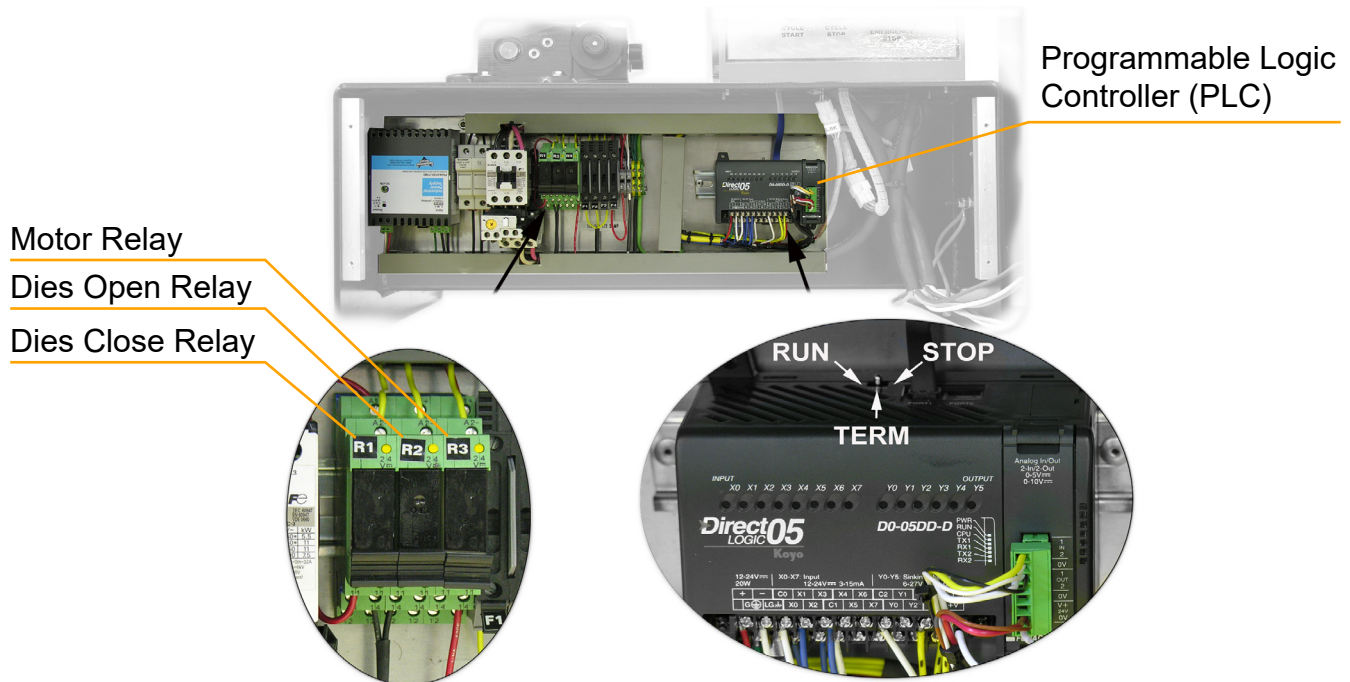

The PLC (Programmable Logic Controller) requires a relatively constant source of electrical power. Power surges, outages or drops in power can cause the PLC to lose its settings. This may result in missing or misplaced information on the controller screen.

### Resetting the PLC to its original settings is a simple procedure

- › Turn the main power switch to **OFF**.
- › Remove the 4 screws holding the front panel in place and set the panel aside without disconnecting any wires.
- › Power up the crimper from the main power switch. The crimper must be powered on during the PLC reset procedure.
- › Move the three position toggle switch on top of the PLC right to the **STOP** position and then left to the **RUN** position.
- › Return the toggle switch to the center **TERM** position.
- › Turn the main power switch to **OFF** and replace the front panel.
- › The PLC and the crimper should now operate normally.

### Relay replacement

- › There are 3 relays which control the motor operation and dies open and dies close functions of the crimper. If one of these functions is inoperable, these relays can be replaced.
- › If the pilot light adjacent to the “R1”, “R2” and “R3” is lit and the function does not operate, this indicates the relay is receiving power but not performing its function.
- › All 3 relays are identical and interchangeable.

# Replacement Parts List

## Part Number

## Description

PC200/400 – PLC	PLC (Need Machine's Serial Number)
PC200/400 – Touch Panel	Touch Panel
PC200/400 – Potentiometer	Linear Potentiometer
PC200/400 – Power Supply 230V	230V Power Supply
PC200/400 – Power Supply 480V	480V Power Supply
PC200/400 – Relay Block Assembly	Fully Assembled Relay Block
PC200/400 – Transducer	Pressure Transducer
PC200/400 – E-Stop	Emergency Stop Button
PC200/400 – Push Button	Close/Open Push Button
PC200/400 – 5AMP Fuse	5 AMP 600V Midget Fuse
PC200/400 – 3AMP Fuse	3 AMP 250V Fast Action Fuse
PC200/400 – 1/2AMP Fuse	1/2 AMP 250V Fast Action Fuse
PC200/400 – Grease	Tube of Grease
PC200/400 – Grease Nipple	Grease Nipple for Grease Gun
PC200/400 – Intermediate Tool	Intermediate Die Removal Tool
PC200/400 – DCT	Die Change Tool
PC400 – Protection Pad	Foam Protection Pad
PC200/400 – Foot Pedal	Foot Pedal
PC200 – Die Screw	Die Stud for Hydraulic Dies
PC400 – Die Screw	Die Stud for Industrial Dies



Hydraulic Die Screw



Industrial Die Screw

For technical assistance, call customer service at **1-800-235-4632**. The Continental ContiTech branded crimper is covered under the warranty below.

#### CustomCrimp® “No Nonsense” warranty

All CustomCrimp® products are warranted to be free of defects in workmanship and materials for one year from the date of invoice. This warranty ends when the product becomes unusable for reasons other than defects in workmanship or material.

If any product or part manufactured by CustomCrimp® is found to be defective by CustomCrimp®, at its option CustomCrimp® will either repair or replace the defective part or product and return via ground transportation, freight prepaid.

This warranty does not cover any product or part which is worn out, abused, altered, used for a purpose other than for which it was intended or used in a manner which was inconsistent with any instructions regarding its use.

Electric motors are separately warranted by their manufacturer under the conditions stated in their separate warranty.

## Industrial Fluid Solutions

Market segment  
Hydraulic Hose

Contact  
ContiTech  
703 S. Cleveland Massillon Road  
Fairlawn, OH 44333-3023 U.S.A.  
1-800-235-4632  
[www.contitech.us](http://www.contitech.us)

Your local contact  
[www.contitech.de/contactlocator](http://www.contitech.de/contactlocator)

Canada  
1-888-275-4397

Mexico  
1-800-439-7373

## Continental. Smart Solutions Beyond Rubber

The ContiTech division of the Continental Corporation is one of the world's leading industry specialists. As a technology partner, our name is synonymous with expertise in development and materials for components made of natural rubber and plastics and also in combination with other materials such as metal, fabrics or silicone. By integrating electronic components, we are also generating solutions for the future.

Beyond products, systems and services, we also provide holistic solutions and have a formative influence on the industrial infrastructure. We see digitalization and current trends as an opportunity to work with our customers to add sustainable value – for both sides and for good.

Rev: 08/13/2019